

BROILER CHICKEN INDUSTRY

SAFE WORK PRACTICES

Implementation date: January 1, 2011

Published: September 2010

First edition brought to you by



TABLE OF CONTENTS

Broiler Chicken Industry Safe Work Practices (BCISWP) Disclaimer	4
Forward	5
BCISWP Defined	6
How to Use the BCISWP	7
INTRODUCTION	
Using the BCISWP within a Five Step Health and Safety Management System	11
General Legislation	13
JOB PLANNING	
Areas of Responsibility	17
Work In A Safe Environment	19
WORK PRACTICES	
Placing Broiler Chicks in Barn	23
Loading on Truck/Catching Broiler Chickens in Barn	27
Working on Live Haul Broiler Transport Trailers -- Equipped with Manual Tarp System	32
Working on Live Haul Broiler Transport Trailers -- Equipped with Solid Roof	35
GLOSSARY & APPENDICES	
Glossary of Terms	39
Appendix A - Legislation:Construction Regulation 213/91	41
Appendix B - Legislation: Canada Occupational Health and Safety Regulation SOR 86-304	47
Appendix C - Engineered Drawings for Barns with Second and Third Floors	51

BROILER CHICKEN INDUSTRY SAFE WORK PRACTICES

DISCLAIMER

The contents of the Broiler Chicken Industry Safe Work Practices (BCISWP), including all advice, recommendations and procedures are provided as a service by Workplace Safety & Prevention Services. No representation of any kind is made to any person whatsoever with regard to accuracy, completeness or sufficiency of the material. Any and all use of these practices, or anything found herein, is solely and entirely at the user's risk.

Workplace Safety & Prevention Services wishes to express its appreciation to those who have assisted in the preparation of the Broiler Chicken Industry Safe Work Practices Manual.

FOREWORD

In an effort to further the safety of the worker in Ontario, the *Broiler Chicken Industry Safe Work Practices* (BCISWP) was developed. It cannot be stressed enough that this is a living document, a work in progress. Though further research and development of new techniques may appear in the industry, with the use of this document we endeavour to set a guideline for safety in the workplace by which new techniques can be judged for safety.

To address the lack of documented safety guidelines for the poultry industry, an industry representative group convened to create the *Broiler Chicken Industry Safe Work Practices*. The practices outline the minimum requirements for poultry workers to work safely in Ontario. The BCISWP Committee included representatives from the following groups who were instrumental in creating the BCISWP:

Poultry Service Association
Chicken Farmers of Ontario
Association of Ontario Chicken Processors
Ontario Independent Poultry Processors
Workplace Safety & Prevention Services
Transportation Health and Safety Association of Ontario
Ontario Ministry of Agriculture, Food & Rural Affairs

The purpose of the BCISWP is to:

- increase safety in the workplace;
- provide safe work practices to follow when performing work on broiler chicken farms; and
- create a guideline for curriculum and training program development.

BROILER CHICKEN INDUSTRY SAFE WORK PRACTICES DEFINED

SCOPE

The Broiler Chicken Industry Safe Work Practices contain safety requirements for handling of live broiler chickens and for using equipment to perform these activities on broiler chicken farm operations.

PURPOSE

The work practices provide safety criteria for workers involved in the broiler chicken industry.

APPLICATION

The BCISWP is intended to apply to all employees engaged in the business or trade of working with live broiler chickens on the farm and in transit. The BCISWP serves as a reference for work safety requirements for those engaged in the practice of handling live birds. The safe work practices may require situational modifications in response to personnel emergencies and is not intended to limit the options available to emergency responders.

DETAILS OF BCISWP

The BCISWP contain several pieces of information to be used to create a safe work environment. The user should follow the document and all supporting information.

Each safe work practice document is broken into several sections:

- **Potential Hazards:** hazards that may be encountered while performing the work.
- **Legislation:** legislation that is applicable to the work practice and the supporting BCISWP document.
- **Mandatory Information:** information required to follow when performing the specific work practice.
- **Work Practice:** practices that should be used as a guideline for performing the work.

IMPLEMENTATION DATE

The implementation date for the Broiler Chicken Industry Safe Work Practices is January 1, 2011.

The only exception to this date is the retrofitting of the live haul broiler trailers with either safety rails and harnesses or solid roofs which are not expected to be completed until July 1, 2011.

HOW TO USE THE BCISWP

Ontario's farming sector came under the Occupational Health and Safety Act (OHSA) in 2006. To address and highlight the unusual hazards found on farms, Occupational Health and Safety Guidelines were developed by representatives from the farming community, Farm Safety Association, Ontario Ministry of Agriculture, Food and Rural Affairs and Ontario Ministry of Labour. Components of the OHS Guidelines have been referenced in the development of the BCISWP.

The development of the BCISWP included a review of legislative requirements found under the OHSA guidelines where applicable. The Safe Work Practices do not supersede legislative requirements but enhance what is found there. The BCISWP do not supersede what is found in any manufacturer's instructions.

In developing the BCISWP, each task was broken down to its most basic components and from those, a safe work practice was developed. There are no procedures in the BCISWP but a series of suggested practices to follow. Any task may be performed utilizing one or more practices, but the basic safety steps will always be the same no matter how the task is performed.

Within the BCISWP words that have been **bolded** and/or are in *italics* are defined in the ***Glossary of Terms***.

INTRODUCTION

Using the Broiler Chicken Industry Safe Work Practices Within the Five Step Health and Safety Management System

General Legislation

USING THE BROILER CHICKEN INDUSTRY SAFE WORK PRACTICES WITHIN THE FIVE STEP HEALTH & SAFETY MANAGEMENT SYSTEM

The Broiler Chicken Industry Safe Work Practices are safe work guidelines, written by the industry, for the industry. They are recognized and supported by the organizations identified on the acknowledgement pages of this manual.

BCISWP do not, on their own, ensure that there will be safety on the job. To effectively implement the BCISWP, there has to be a systematic approach to managing these within a health and safety program. “*The Five Steps to Managing Health & Safety*” provides a management system approach. The following graphic depicts the Health & Safety management model. A systematic approach is critical to a successful health and safety program.

The BCISWP fall under the program element of Control Activities in the Five Step model. Each safe work practice is managed by using the five steps. The industry working group has established the safe work practice as a guideline for the sector. Employers are responsible to communicate, train, implement and ensure that the practice is actually followed. Based on evaluation; recognition of success is given and improvements made when needed. This is the continuous improvement loop.

The Five Step model is incorporated in the Workplace Safety and Insurance Board (WSIB) Safe Workplace Awareness Program (SWAP) which has formed the basis for the *Safe Communities Incentive Program* (SCIP) and *Safety Groups*. For purposes of the BCISWP, this manual provides an introduction to the Five Step model. For further information on the Five Step model and the full SWAP, contact the WSIB at 1-800-663-6639.

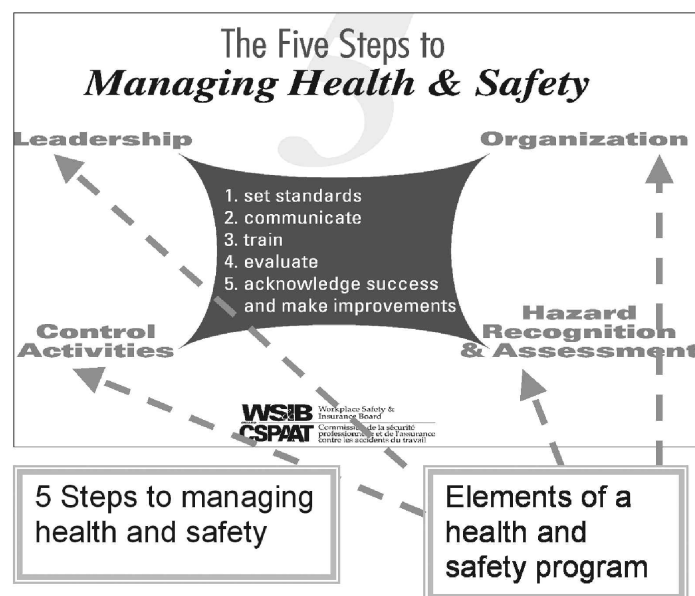

“THE FIVE STEPS TO MANAGING HEALTH & SAFETY”

1. SET STANDARDS

Setting standards means the standards, expectations, and policies regarding health and safety that have been developed by the industry. A decision to use BCISWP, which have been created and supported by the industry, is an example of setting standards for the sector. Another example is setting standards around doing accident investigation or ensuring Health and Safety Representative training.

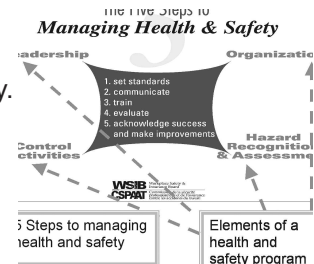

2. COMMUNICATE

Communicating standards and expectations means that the employer ensures all people in the workplace understand the safe work practices, what is expected of them and what they can expect from others. This can happen through formal training programs, notices, meetings, etc.

3. TRAINING

Training means that the manager, supervisor and workers all receive health and safety training relevant to safe work practices. This can include training on use of equipment, including company standards for that equipment or other information appropriate for their role and responsibility, such as the Joint Health and Safety Committee. Job and workplace orientation is an example of training that everyone should receive when they are first hired, change locations or after a long absence from the workplace. Training in BCISWP should be ongoing.

4. EVALUATE

Evaluation means that each sector of the industry reviews compliance to its own expectations. Actual health and safety activity and use of BCISWP is compared against industry expectations, to ensure they are being met. Evaluation techniques include supervision, interview and observation. The standard itself should be assessed to ensure that it still meets legal minimums and is valid and appropriate for the workplace.

5. ACKNOWLEDGE SUCCESS AND MAKE IMPROVEMENTS

Acknowledge and congratulate those who follow or contribute to maintaining industry standards. Due diligence includes correcting and improving any weak areas in the health and safety program.

The Five Steps for Managing Health and Safety are applied to each element of a health and safety program.

GENERAL LEGISLATION

The following sections of the Occupational Health and Safety Act (OHSA) apply to the broiler chicken industry and form the foundation for all of the Broiler Chicken Industry Safe Work Practices. It should be noted that the applicable legislation sets minimum standards for the trade. Specific legislation relating to a work practice will be indicated in each individual work practice section.

LEGISLATION

Note: Not all sections of the OHSA and Regulations have been indicated here or included in the BCISWP. It is the responsibility of individuals to know and understand applicable legislation and apply them as required.

- OHSA 25 (1) (a) Duties of Employer: ensure that the equipment, materials and protective devices **as prescribed** are provided.
- OHSA 25 (1) (b) Duties of Employer: ensure that the equipment, materials and protective devices provided by the employer are maintained in good condition.
- OHSA 25 (1) (d) Duties of Employer: ensure that the equipment, materials and protective devices provided by the employer are used **as prescribed**.
- OHSA 25 (2) (a) Duties of Employer: provide information, instruction and supervision to a worker to protect the health or safety of the worker.
- OHSA 25 (2) (h) Reasonable Precautions: take every precaution reasonable in the circumstances for the protection of a worker.
- OHSA 26 (1) (k) Additional Duties of Employers: where so prescribed provide a worker with written instructions as to the measures and procedures to be taken for the protection of a worker.
- OHSA 27 (1) (a) Duties of a Supervisor: *shall* ensure that a worker works in a manner and with the protective devices, measures and procedures required by this Act and the regulations.
- OHSA 27 (1) (b) Duties of a Supervisor: *shall* ensure that a worker uses or wears the equipment, protective devices or clothing that the worker's employer requires to be used or worn.
- OHSA 27 (2) (b) Duties of a Supervisor: *shall* where so prescribed, provide a worker with written instructions as to the measures and procedures to be taken for the protection of the worker.
- OHSA 2 (c) Duties of a Supervisor: protection of worker.
- OHSA 28 (1) (a) Duties of Worker: *shall* work in compliance with the provisions of this Act and the regulations.
- OHSA 28 (1) (b): Duties of Worker: *shall* use or wear the equipment, protective devices of clothing that the worker's employer requires to be used or worn.

JOB PLANNING

Areas of Responsibility

Work in a Safe Environment

AREAS OF RESPONSIBILITY

The work of delivering broiler chicks to the barn and catching/hauling live broiler chickens from the farm to the processing plant involves many partners in Ontario. All groups involved have a role to play in the overall goal of providing a safe work environment. Keep in mind that specific risks need to be managed by appropriate industry groups.

Farmer

Responsible for the barn structures and farm yard (Refer to Appendix C). This includes any safety equipment associated with the barn (e.g. fan guarding, guard rails on loading ramps, hand rails in the stairways, etc.). Farmers are required to conduct periodic inspection and maintenance of the farm structures and equipment. This includes the yard/driveway, ensuring adequate overhead clearance for trucks, driveway maintenance, etc. Farmer must communicate any known hazards on the property to other parties prior to the work activity starting.

Transport Company

Responsible for all safety equipment associated with the truck, its installation, inspection and on-going maintenance. They are responsible for providing safety training to their employees and ensuring the employees are following the procedures outlined in the Broiler Chicken Industry Safe Work Practice (BCISWP) manual when loading birds.

Catching Company

Responsible for providing all identified Personal Protective Equipment (PPE) to their employees (e.g. dust masks). They are responsible for providing safety training to their staff and ensuring the employees are following the procedures outlined in the BCISWP manual.

Processing Company

As the group that hires the catching and hauling companies, they are responsible for ensuring that only companies that have adopted the BCISWP manual for loading and hauling chickens are hired.

Hatchery Company

Responsible for all safety equipment associated with the chick delivery truck and for providing any PPE to their employees. They are responsible for providing safety training to their staff and ensuring that employees are following the procedures outlined in the BCISWP manual.

WORK IN A SAFE ENVIRONMENT

INTRODUCTION

The purpose of this section is to outline the requirements for establishing and maintaining a safe work environment.

HAZARDS*

Biotic Conditions

Gravity

Chemical

Mechanical

Climatic Conditions

Pedestrian

Electrical

Vehicular

Ergonomics

LEGISLATION

General Legislation

Occupational Health and Safety Guidelines for Farming Operations in Ontario

Legislation	Regulation No.	Section Referenced
Construction	213/91	21

MANDATORY INFORMATION

The following are the general requirements for establishing and ensuring a safe work environment:

- All hazards at the work site must be identified, mitigated and communicated to all workers prior to starting work.
- The work site must be continually monitored for changes to hazards and appropriate barriers put in place.
- A first aid kit must be available.
- Barn should have legible sign with farm manager/owner phone number, address and 911# in case of emergency and help needs to be called.
- All external ramps on barn should have reflective tape or markers to increase their visibility for drivers positioning truck alongside the barn.
- Personnel are on site and fit to work (not under the influence of drugs or alcohol).
- All parties involved on the worksite shall have liability insurance coverage.

* The hazards **bolded** at the beginning of each protocol are those considered to be present for the practices described.

WORK PRACTICE

Farmer (or site manager) and authorized personnel (crew supervisor) should inspect the work areas to identify hazards prior to starting work. Any workplace hazards or issues identified should be verbally communicated to all crew members prior to starting work.

The farmer (or site manager) should be present at the start of work activities and available throughout the balance of work activities.

STEP	ACTION
Inspect bird housing area and load out doors for work hazards	Identify hazards <ul style="list-style-type: none"> ● fall and trip hazards ● overhead clearance – suspended equipment ● mechanical hazards – fans ● environmental conditions (weather, temperature, etc.) ● biotic conditions (e.g. dust, ammonia levels, dead birds, etc.)
Provide barriers (safety systems) to protect workers (Refer to Appendix C)	<ul style="list-style-type: none"> ● fall prevention railings ● secure work platforms ● fan guards in place ● no build up of ice and snow on load out ramps

WORK PRACTICES

Placing Broiler Chicks in Barn

Loading on Truck/Catching Broiler Chickens in Barn

Working on Live Haul Broiler Transport Trailers
-- Equipped with Manual Tarp System

Working on Live Haul Broiler Transport Trailers
-- Equipped with Solid Roof

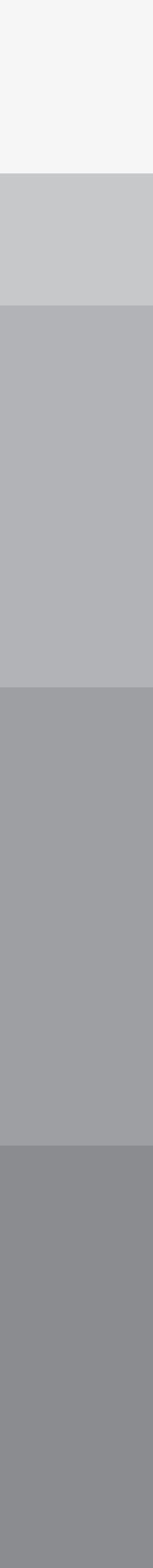

PLACING BROILER CHICKS IN BARN

INTRODUCTION

This section outlines safe work practice for placing broiler chicks in the barn.

HAZARDS*

Biotic Conditions

Mechanical

Electrical

Gravity

Climatic Conditions

Vehicular

Chemical

Pedestrian

Ergonomics

LEGISLATION

General Legislation

Work in a Safe Environment

Occupational Health and Safety Guidelines for Farming Operations in Ontario

Legislation	Regulation No.	Section Referenced
Construction	213/91	21, 26.3, 125

MANDATORY INFORMATION

The following are the general mandatory requirements for all personnel placing broiler chicks in barn:

- All appropriate Personal Protective Equipment (PPE) shall be worn while workers are placing broiler chicks, i.e. N95 dust masks.
- Barn must be prepared before workers enter space, i.e. feed lines and water lines have been raised so workers can walk without obstructions over which they may trip. Equipment shall be raised as high as possible to prevent workers striking their heads. Ventilation system is operating to provide fresh air and remove contaminants from barn area for the duration of loading.
- Straw or shavings should be cleared to floor to make a path to roll stacks of chicks to brooding area.
- In multi-storey barns, all floor openings (not used for passing chicks) are properly closed and secured.
- Ventilation system is operating to provide fresh air and removal of contaminants from barn area for duration of placement.
- All required safety guards are in place over ventilation equipment (fan guards) so a person could not contact any moving fan parts.
- Stairways between floors are well lit, free of clutter and have a hand rail in place.

* The hazards **bolded** at the beginning of each protocol are those considered to be present for the practices described.

WORK PRACTICE

1.0 Chick Placing Procedure

PLACING CHICKS GROUND FLOOR	
STEP	ACTION
Inspect load out doors and area adjacent to doors	<p>Ensure all load out doorways are in good state of repair – no sharp objects protruding from frame. The area outside the door must be level and clear of ice/snow/debris.</p> <p>Check there are no trip hazards or obstructions in workers' path.</p>
Truck placement	<p>Drive the truck along side the barn as close to the loading/unloading doors as possible.</p> <p>Set the truck platform (if it exists).</p> <p>Open truck door and proceed to unload chick boxes.</p>
Pass chick boxes into barn	<p>Personnel on truck pass chick boxes to personnel in the barn doorway. Personnel stack chick boxes in designated area until correct volume unloaded for that floor. They move the boxes to the designated placement area in the barn and empty chicks onto floor. Personnel return empty chick boxes to doorway and load them into the truck.</p>
Relocate truck	<p>Move truck to next door if necessary and repeat process.</p>

PLACING CHICKS SECOND FLOOR	
STEP	ACTION
Set loading platform (Refer to Appendix C)	<p>Fixed ramps – carefully maneuver truck into position beside barn without contacting ramp.</p> <p>Folding ramps - Once transport truck is in place beside the barn, unfold the steel load out ramp, ensure the ramp is level by adjusting support chains.</p> <p>Install steel side rails in pockets on barn and ramp (if rails not permanently affixed).</p> <p>Test side rail is in place by applying slight horizontal pressure to side rail.</p>
Pass chick boxes	<p>Personnel on truck pass chick boxes to personnel standing on second floor ramps. Personnel stack chick boxes in designated area until correct volume unloaded for that floor. Boxes are moved to the designated placement area in the barn and the chicks are emptied onto floor. Personnel return empty chick boxes to doorway and load them into the truck.</p>
Retract loading platform	<p>When all chicks are placed, remove side rails.</p> <p>For folding steel ramps – fold ramp back up into door frame.</p> <p><u>Note:</u> caution should be taken when relocating truck to not damage the loadout ramps.</p>

PLACING CHICKS THIRD FLOOR

STEP	ACTION
Inspect pass through holes and load out equipment present in the barn	<p>Second floor determine location of 30 in. x 48 in. (76 cm x 122 cm) openings for passing chicks relative to loadout doors.</p> <p>Ensure portable construction/industrial grade Canadian Standard Association (CSA) approved scaffold unit or equivalent with secured non-slip work platform is present on second floor.</p> <p>Ensure no feed or water lines present under floor opening that could impede workers.</p> <p>Third floor ensure guard rail system to place around floor openings is present.</p>
Set up loading equipment in barn (Refer to Appendix C)	<p>Second floor - set up scaffold unit directly under pass through hole. Ensure scaffold is level and work platform is secure.</p> <p>Third floor - remove floor panel and secure guard rail system around floor opening.</p>
Receive chick boxes	<p>Personnel on truck passes chick box to personnel on second floor loading ramp. This individual moves boxes into barn and passes them to personnel standing on scaffold unit. Personnel on scaffold passes chick box up through floor hole to personnel on third floor who move boxes to designated placement area and empty chicks onto floor.</p> <p>Personnel on third floor return empty chick boxes to floor hole where they are passed down to personnel on second floor scaffold and then moved to doorway and passed to personnel in the truck.</p>
Dismantle loading equipment	<p>When all chicks have been placed on third floor:</p> <ul style="list-style-type: none"> ● remove safety guard rail around floor opening; ● secure floor panel over floor opening and replace bedding over cover; and, ● move safety guard rail to next floor pass through and repeat process (if necessary). <p>Second floor - move scaffold unit to next pass through; repeat set up directly under this opening.</p>

LOADING ON TRUCK/CATCHING BROILER CHICKENS IN BARN

INTRODUCTION

This section outlines safe work practice for catching/loading broiler chickens from barn.

HAZARDS*

Biotic Conditions

Mechanical

Electrical

Gravity

Climatic Conditions

Vehicular

Chemical

Pedestrian

Ergonomics

LEGISLATION

General Legislation

Work in a Safe Environment

Occupational Health and Safety Guidelines for Farming Operations in Ontario

Legislation	Regulation No.	Section Referenced
Construction	213/91	21, 26.3, 125

MANDATORY INFORMATION

The following are the general mandatory requirements for all personnel catching/handling broiler chickens in barn:

- All appropriate Personal Protective Equipment (PPE) shall be worn while catching and loading broiler chickens, i.e. N95 dust masks.
- Barn must be prepared before catchers enter space, i.e. feed lines and water lines have been raised so catchers can walk without obstructions over which they may trip. Equipment shall be raised as high as possible to prevent workers striking their heads. Ventilation system is operating to provide fresh air and remove contaminants from barn area for the duration of loading.
- All required safety guards are in place over ventilation equipment (fan guards) so a person could not contact any moving fan parts.
- Stairways between floors are well lit, free of clutter and have a hand rail in place.
- Lighting at loading doors that is dimmable is recommended.
- All external ramps on barn should have reflective tape or markers to increase their visibility for drivers positioning truck alongside the barn.
- Eaves trough located over load out doors
- Roof above load out doors must be clear of ice and snow to protect personnel from falling hazards.

* The hazards **bolded** at the beginning of each protocol are those considered to be present for the practices described.

WORK PRACTICE

1.0 Loading Procedure

LOADING GROUND FLOOR	
STEP	ACTION
Inspect load out doors and area adjacent to doors	<p>Ensure all load out doorways are in good state of repair – no sharp objects protruding from the building.</p> <p>The area outside the door is level and clear of ice/snow/debris.</p> <p>No trip hazards or obstructions in work area.</p>
Set loading equipment between barn and truck	<p>Set work platform between truck and barn for personnel to stand on for passing chickens from barn up to personnel on truck. Ensure work surface is level. Work platform must have a non-slip surface to provide good traction.</p>
Catch and pass birds	<p>Catch broiler chickens in barn section near door and carry them to the load out doors. Personnel in barn pass birds to personnel on platform/scaffold, who pass them to personnel on the trailer.</p>
Move loading platform to next door	<p>When all birds adjacent to load out door have been loaded, move platform to next load out door and repeat process.</p>

LOADING SECOND FLOOR	
STEP	ACTION
<p>Inspect second floor load out doors and load out ramps. (Folding steel ramps, fixed steel ramps and fixed wood ramps) (Refer to Appendix C)</p>	<p>Ensure all load out doorways are in good state of repair – no sharp objects protruding from the building.</p> <p>Load out ramps are securely fastened to barn, free of debris and in good state of repair, i.e. support chains or braces properly fastened.</p> <p>Pocket system to receive side rails is attached to barn and ramp for portable rails.</p> <p>Steel side rails permanently attached to ramps or present on site for quick installation (portable system).</p>
<p>Position truck/ramps</p>	<p>Drive the truck along side the barn as close to the loading ramps as possible without contacting ramp. For folding ramps ensure the ramp is level by adjusting support chains.</p> <p>Ensure steel side rails are in place prior to start of catching. Test side rail is secured in place by applying slight horizontal pressure to side rail.</p> <p>For subsequent doors, ensure steel side rails are in place prior to loading from these doors. Test side rail is secured in place by applying slight horizontal pressure to side rail.</p>
<p>Catch and pass birds</p>	<p>Personnel catch broiler chickens in area and carry them to the load out doors. Once on the ramp, they pass birds to personnel on the trailer.</p>
<p>Moving truck</p>	<p>When all birds adjacent to load out doors have been loaded, remove side rails (if necessary), and close load out door.</p> <p><u>Note:</u> Caution should be taken when relocating truck to not damage the load out ramps.</p>

LOADING THIRD FLOOR

STEP	ACTION
<p>Inspect pass through holes and load out equipment present in the barn</p>	<p>Second floor - determine location of 30 in. x 48 in. (76 cm x 122 cm) openings for passing birds relative to load out doors.</p> <p>Ensure portable construction/industrial grade Canadian Standard Association (CSA) approved scaffold unit or equivalent with secured non-slip work platform is present and set up on second floor.</p> <p>Ensure no equipment (feed or water lines) present under floor opening that could impede workers.</p> <p>Third floor ensure guard rail system to place around floor openings is present. Pass through holes have been located and litter cleared from over the door.</p>
<p>Set up loading equipment in barn (Refer to Appendix C)</p>	<p>Second floor - set up scaffold unit directly under pass through hole. Ensure scaffold is level and work platform is secure.</p> <p>Third floor - Remove floor panel and secure guard rail system around floor opening.</p>
<p>Catch and pass birds</p>	<p>Personnel on third floor catch and pass birds through floor hole to personnel standing on scaffold (second floor). Individual on scaffold pass birds to personnel on second floor who carries birds out second floor load out doors where they are passed to personnel on the trailer.</p>

LOADING THIRD FLOOR	
STEP	ACTION
Move loading equipment between holes (Refer to Appendix C)	<p>When all birds around third floor pass through have been caught:</p> <ul style="list-style-type: none"> ● remove safety guard rail around third floor opening; ● secure floor panel over floor opening; and, ● move safety guard rail to next floor pass through and repeat process. <p>Second floor - move scaffold unit to next pass through; repeat set up directly under this opening.</p>
Dismantle loading equipment	<p>When all birds around third floor pass through have been caught:</p> <ul style="list-style-type: none"> ● remove safety guard rail around third floor opening and store ● secure floor panel over opening ● remove second floor scaffold unit and store

WORKING ON LIVE HAUL BROILER TRANSPORT TRAILERS – EQUIPPED WITH MANUAL TARP SYSTEM

INTRODUCTION

This section outlines the safe work practice for working on live haul broiler transport trailers equipped with manual tarp system

HAZARDS*

Biotic Conditions	Gravity	Chemical
Mechanical	Climatic Conditions	Pedestrian
Electrical	Vehicular	Ergonomics

LEGISLATION/SAFE WORK PRACTICE

General Legislation

Work in a Safe Environment

Occupational Health and Safety Guidelines for Farming Operations in Ontario

Legislation	Regulation No.	Section Referenced
Canada Occupational Health & Safety Regulation	SOR 86-304	12.1, 12.10, 12.15
Construction	213/91	21, 26.4

MANDATORY INFORMATION

The following are the general mandatory requirements for all personnel working on live haul trailers at heights greater than eight feet (2.4 m) above ground:

- Top of live haul trailer equipped with engineered anchorage system capable of supporting two personnel at the same time.
- Ensure end stops are mounted on engineered anchorage system to prevent personnel from getting too close to the ends of trailer.
- Personnel are supplied with CSA approved, five-point safety harness and appropriate Y-lanyard.
- Personnel are trained to properly fit safety harness.
- Personnel are trained how to properly inspect safety harness and lanyard for defects.
- Truck driver is responsible for setting up the truck for loading, moving the truck forward, catching strays, crates passed down at end of load, and tarping and chaining in preparation for transport. In some cases, the truck driver may also be involved in loading birds.
- Catchers will assist with chaining and tarping in inclement weather situations.
- Trucks should be equipped with a movement alert/alarm system that is activated when the truck is being moved during loading.

* The hazards **bolded** at the beginning of each protocol are those considered to be present for the practices described.

STEP	ACTION
<p>Prior to ascending onto trailer</p>	<p>Inspect intended loading/parking area beside barn for trailer. Ensure area is level and free of ice and snow accumulation that could cause trailer to slant. Open sliding curtain on barn side of trailer (possibly both sides).</p> <p>Release straps or chain binders securing crates on trailer.</p> <p>Inspect safety harness and lanyard for any defects. Replace either if defects are found.</p> <p>Put on safety harness.</p>
<p>Ascend trailer</p>	<p>Climb trailer ladder maintaining three-point contact on ladder.</p> <p>At the top of ladder (maintain three-point contact), attach lanyard to engineered anchorage system using carabineers provided.</p> <p>Once attached to anchorage system, climb on top of trailer.</p>
<p>Prepare trailer for receiving birds</p>	<p>Walk along top of trailer and remove straps/chains/tarps when used from barn side of trailer.</p> <p>Remove required number of crates from first and second rows on trailer to create a workspace in trailer to start receiving birds from barn.</p>

STEP	ACTION
Receive birds from barns	<p>All personnel standing on the trailer with their feet greater than eight feet (2.4 m) above ground should be wearing safety harness and be tied off to anchorage system.</p> <p>Personnel on the trailer receiving birds whose feet are less than eight feet (2.4 m) above the ground are not required to be restrained but should take reasonable precautions to prevent falls.</p>
Prepare trailer for highway travel	<p>Personnel on top of load shall be wearing safety harness and be attached to anchorage system with lanyard.</p> <p>Walk along top of trailer and apply straps/chains over crates.</p> <p>Walk along top of trailer and apply top tarp if required.</p> <p>During inclement weather/as determined by driver, catchers are required to stay on trailer and aid driver with preparation of trailer for transport.</p>
Descend from trailer	<p>Move to back of trailer.</p> <p>Climb onto trailer ladder maintaining three-point contact.</p> <p>Disconnect lanyard from anchorage system, descend to ground.</p>

Working on Live Haul Broiler Transport Trailers – Equipped with Solid Roof

INTRODUCTION

This section outlines the safe work practice for working on live haul broiler transport trailers that are equipped with a solid roof system.

HAZARDS*

Biotic Conditions

Gravity

Chemical

Mechanical

Climatic Conditions

Pedestrian

Electrical

Vehicular

Ergonomics

LEGISLATION/SAFE WORK PRACTICE

General Legislation

Work in a Safe Environment

Occupational Health and Safety Guidelines for Farming Operations in Ontario

Legislation	Regulation No.	Section Referenced
Canada Occupational Health & Safety Regulation	SOR 86-304	12.1, 12.10, 12.15
Construction	213/91	21, 26.4

MANDATORY INFORMATION

The following are the general mandatory requirements for all personnel working on live haul trailers at heights greater than eight feet (2.4 m) above ground:

- Truck driver is responsible for setting up the truck for loading, moving the truck forward, catching strays, crates passed up at end of load, and tarping and chaining in preparation for transport. In some cases, the truck driver may also be involved in loading birds.
- Trucks should be equipped with a movement alert/alarm system that is activated when the truck is being moved during loading.

* The hazards **bolded** at the beginning of each protocol are those considered to be present for the practices described.

STEP	ACTION
Preparing trailer	<p>Inspect intended loading/parking area beside barn for trailer. Ensure area is level and free of ice and snow accumulation that could cause trailer to slant.</p> <p>Open sliding curtain on barn side of trailer (possibly both sides).</p> <p>Release straps or chain binders securing crates on trailer.</p>
Set work platform	<p>Set work platform between truck and barn for personnel to stand on for prepping the trailer for loading and for passing chickens from barn up to personnel on truck. Ensure work surface is level. Work platform must have a non-slip surface to provide good traction.</p>
Prepare trailer for receiving birds	<p>Raise roof on trailer to accommodate loading activities. While standing on the platform remove the required number of crates from first and second rows on trailer and set them on the ground beside barn. This creates a workspace in trailer to start receiving birds from barn.</p>
Receive birds from barns	<p>Personnel on the trailer receiving birds whose feet are less than eight feet (2.4 m) above the ground are not required to be restrained but should take reasonable precautions to prevent falls.</p>
Finish loading trailer	<p>Reload crates that were previously placed on the ground (to start the load) and fill with birds.</p> <p>Final crates are placed on truck by personnel standing on work platform beside the truck.</p>
Prepare trailer for highway travel	<p>Walk along side of trailer and apply straps/chains to secure the crates.</p> <p>Ensure roof is lowered and locked. Walk along side of trailer and apply tarp/curtains if required.</p>

GLOSSARY & APPENDICES

Glossary of Terms

Appendix A - Legislation: Construction Regulation 213/91

Appendix B - Legislation: Canada Occupational
Health and Safety Regulation SOR 86-304

Appendix C - Engineered Drawings for Barns with
Second and Third Floors

GLOSSARY OF TERMS

Biotic condition	Conditions such as dust, dander, feathers, birds, etc.
Chemical conditions	Ammonia, carbon dioxide, etc.
Climatic conditions	Rain, snow, freezing rain, winds, cold or hot temperatures on trailer or loadout ramps
Fall protection system	Fall protection system can be a fall restraint system or fall restriction system
Fall restraint system	Means an assembly of components capable of restricting a worker's movement on a work surface and preventing the worker from reaching a location from which he or she could fall
Fall restriction system	Means a type of fall protection system that has been designed to restrict a worker's fall to a specific distance

APPENDIX A

LEGISLATION CONSTRUCTION REGULATION 213/91

NOTE

This section does not contain the full Construction Regulation 213/91 only selected passages

- 21.** (1) A worker shall wear such protective clothing and use such personal protective equipment or devices as are necessary to protect the worker against the hazards to which the worker may be exposed. O. Reg. [213/91](#), s. 21 (1).
- (2) A worker's employer shall require the worker to comply with subsection (1). O. Reg. [213/91](#), s. 21 (2).
- (3) A worker required to wear protective clothing or use personal protective equipment or devices shall be adequately instructed and trained in the care and use of the clothing, equipment or device before wearing or using it. O. Reg. [213/91](#), s. 21 (3).
- 26.** Sections 26.1 to 26.9 apply where a worker is exposed to any of the following hazards:
1. Falling more than 3 meters.
 2. Falling more than 1.2 meters, if the work area is used as a path for a wheelbarrow or similar equipment.
 3. Falling into operating machinery.
 4. Falling into water or another liquid.
 5. Falling into or onto a hazardous substance or object.
 6. Falling through an opening on a work surface. O. Reg. 145/00, s. 12; O. Reg. 85/04, s. 4.
- 26.1** (1) A worker shall be adequately protected by a guardrail system that meets the requirements of subsections 26.3 (2) to (8). O. Reg. 145/00, s. 12.
- (2) Despite subsection (1), if it is not reasonably possible to install a guardrail system as that subsection requires, a worker shall be adequately protected by at least one of the following methods of fall protection:
1. A travel restraint system that meets the requirements of section 26.4.
 2. A fall restricting system that meets the requirements of section 26.5.
 3. A fall arrest system, other than a fall restricting system designed for use in wood pole climbing that meets the requirements of section 26.6.
 4. A safety net that meets the requirements of section 26.8. O. Reg. 145/00, s. 12; O. Reg. 85/04, s. 5 (1).

(3) The components of any system listed in subsection (2) shall be designed by a professional engineer in accordance with good engineering practice, and shall meet the requirements of any of the following National Standards of Canada standards that are applicable:

1. CAN/CSA-Z259.1-95 (R1999): Safety Belts and Lanyards.
2. CAN/CSA-Z259.2.1-98: Fall Arresters, Vertical Lifelines and Rails.
3. CAN/CSA-Z259.2.2-98: Self-Retracting Devices for Personal Fall-Arrest Systems.
4. CAN/CSA-Z259.2.3-99: Descent Control Devices.
5. CAN/CSA-Z259.10-M90 (R1998): Full Body Harnesses.
6. CAN/CSA-Z259.11-M92 (R1998): Shock Absorbers for Personal Fall-Arrest Systems.
7. CAN/CSA-Z259.14-01: Fall Restrict Equipment for Wood Pole Climbing.
8. CAN/CSA-Z259.12-01: Connecting Components for Personal Fall Arrest Systems (PFAS). O. Reg. 85/04, s. 5 (2).

(4) Before any use of a fall arrest system or a safety net by a worker at a project, the worker's employer shall develop written procedures for rescuing the worker after his or her fall has been arrested. O. Reg. 145/00, s. 12.

26.2 (1) An employer shall ensure that a worker who may use a fall protection system is adequately trained in its use and given adequate oral and written instructions by a competent person. O. Reg. 145/00, s. 13.

(2) The employer shall ensure that the person who provides the training and instruction referred to in subsection (1) prepares a written training and instruction record for each worker and signs the record. O. Reg. 145/00, s. 13.

(3) The training and instruction record shall include the worker's name and the dates on which training and instruction took place. O. Reg. 145/00, s. 13.

(4) The employer shall make the training and instruction record for each worker available to an inspector on request. O. Reg. 145/00, s. 13.

26.3 (1) Despite paragraph 1 of section 26, a guardrail system that meets the requirements of this section shall be used if a worker has access to the perimeter or an open side of any of the following work surfaces and is exposed to a fall of 2.4 meters or more:

1. A floor, including the floor of a mezzanine or balcony.
2. The surface of a bridge.
3. A roof while formwork is in place.
4. A scaffold platform or other work platform, runway or ramp. O. Reg. 145/00, s. 14.

(2) One of the following precautions shall be used to prevent a worker from falling through an opening on a work surface:

1. A guardrail system that meets the requirements of this section.
2. A protective covering that,
 - i. completely covers the opening,
 - ii. is securely fastened,
 - iii. is adequately identified as covering an opening,
 - iv. is made from material adequate to support all loads to which the covering may be subjected, and
 - v. is capable of supporting a live load of at least 2.4 kilonewtons per square meter without exceeding the allowable unit stresses for the material used. O. Reg. 145/00, s. 14.
- (3) The guardrail system or protective covering required under subsection (1) or (2) may be removed temporarily to perform work in or around the opening if a worker is adequately protected and signs are posted in accordance with subsections 44 (1) and (2). O. Reg. 145/00, s. 14.
- (4) The following are the specifications for a guardrail system:
 1. It shall have a top rail, an intermediate rail and a toe board.
 2. The intermediate rail may be replaced by material that can withstand a point load of 450 newtons applied in a lateral or vertical downward direction.
 3. The top of the guardrail system shall be located at least 0.9 meters but not more than 1.1 meters above the surface on which the system is installed.
 4. The toe board shall extend from the surface to which the guardrail system is attached to a height of at least 100 millimeters or, if the toe board is made of wood, at least 89 millimeters.
 5. If the guardrail system is located at the perimeter of a work surface, the distance between the edge of the surface and the guardrail system shall not be greater than 300 millimeters. O. Reg. 145/00, s. 14.
- (5) A guardrail system shall be capable of resisting anywhere along the length of the system the following loads when applied separately, without exceeding the allowable unit stress for each material used:
 1. A point load of 675 newtons applied in a lateral direction to the top rail.
 2. A point load of 450 newtons applied in a vertical downward direction to the top rail.
 3. A point load of 450 newtons applied in a lateral or vertical downward direction to the intermediate rail, or midway between the top rail and the toe board.
 4. A point load of 225 newtons applied in a lateral direction to the toe board. O. Reg. 145/00, s. 14.

(6) If the distance between any two adjacent posts of the guardrail system is greater than 2.4 meters, the system shall be capable of resisting the loads specified in subsection (5) increased in proportion to the greater distance between the posts. O. Reg. 145/00, s. 14.

(7) The following additional requirements apply to a guardrail system that is made of wood:

1. The wood shall be spruce, pine or fir (S-P-F) timber of construction grade quality or better.
2. The wood shall be free of sharp objects such as splinters and protruding nails.
3. The system shall have posts that are at least 38 millimeters by 89 millimeters, are securely fastened to the surface and are spaced at intervals of not more than 2.4 meters.
4. The top rail and the intermediate rail shall each be at least 38 millimeters by 89 millimeters. O. Reg. 145/00, s. 14.

(8) The following additional requirements apply to a guardrail system that is made of wire rope:

1. The top rail and intermediate rail shall be made of wire rope that is at least 10 millimeters in diameter, and the rope shall be kept taut by a turnbuckle.
2. The outward deflection of the top rail and intermediate rail resulting from the loads specified in subsection (5) shall not extend beyond the edge of a work surface.
3. The system shall have vertical separators at intervals of not more than 2.4 meters and horizontal supports at intervals of not more than 9 meters.
4. The intermediate rail shall be located midway between the top rail and the toe board. O. Reg. 145/00, s. 14.

26.4 (1) A travel restraint system shall consist of a full body harness with adequate attachment points or a safety belt. O. Reg. 145/00, s. 14.

(2) The full body harness or safety belt shall be attached by a lifeline or lanyard to a fixed support that meets the requirements of section 26.7. O. Reg. 145/00, s. 14.

(3) The travel restraint system shall be inspected by a competent worker before each use. O. Reg. 145/00, s. 14.

(4) If a component of the travel restraint system is found to be defective on inspection, the defective component shall immediately be taken out of service. O. Reg. 145/00, s. 14.

125. (1) A scaffold which meets the requirements of sections 126, 128, 129, 130, 134, 135, 137, 138, 139, 140, 141 and 142 shall be provided for workers where work cannot be done on or from the ground or from a building or other permanent structure without hazard to the workers. O. Reg. [213/91](#), s. 125 (1).

(2) A worker who is on or under a scaffold while it is being erected, altered or dismantled shall be on a part of the scaffold or scaffold platform that meets the requirements of sections 126, 128, 129, 130, 134, 135, 137, 138, 139, 140, 141 and 142. O. Reg. [213/91](#), s. 125 (2).

- 126.** (1) Every scaffold shall be designed and constructed to support or resist,
- (a) two times the maximum load or force to which it is likely to be subjected, without exceeding the allowable unit stresses for the materials of which it is made; and
 - (b) four times the maximum load or force to which it is likely to be subjected without overturning. O. Reg. [213/91](#), s. 126 (1).
- (2) Despite clause (1) (a), a scaffold with structural components whose capacity can only be determined by testing shall be designed and constructed to support or resist three times the maximum load or force to which it is likely to be subjected without causing the failure of any component. O. Reg. [213/91](#), s. 126 (2).
- (3) No scaffold shall be loaded in excess of the load that it is designed and constructed to bear. O. Reg. [213/91](#), s. 126 (3).

- 128.** (1) Every scaffold,
- (a) shall have uprights braced diagonally in the horizontal and vertical planes to prevent lateral movement;
 - (b) shall have horizontal members that are adequately secured to prevent lateral movement and that do not have splices between the points of support;
 - (c) shall have footings, sills or supports that are sound, rigid and capable of supporting at least two times the maximum load to which the scaffold may be subjected without settlement or deformation that may affect the stability of the scaffold;
 - (d) shall have all fittings and gear, including base plates or wheels, installed in accordance with the manufacturer's instructions;
 - (e) shall have connecting devices between frames that provide positive engagement in tension and compression;
 - (f) shall have safety catches on all hooks; and
 - (g) shall be adequately secured at vertical intervals not exceeding three times the least lateral dimension of the scaffold, measured at the base, to prevent lateral movement. O. Reg. [213/91](#), s. 128 (1).
- (2) A scaffold shall be constructed of suitable structural materials and, if lumber is used, it shall be construction grade or Number 1 Grade spruce. O. Reg. [213/91](#), s. 128 (2).
- (3) A scaffold mounted on pneumatic tires shall not be supported by the pneumatic tires while the scaffold is being erected, used or dismantled. O. Reg. [213/91](#), s. 128 (3).
- (4) If tubular metal frames are used to support masonry units on a scaffold platform, each frame leg shall have a minimum working load of,
- (a) twenty-two kilonewtons for standard frames; and
 - (b) 16.7 kilonewtons for walk-through frames. O. Reg. [213/91](#), s. 128 (4).

- 129.** (1) A scaffold mounted on castors or wheels,
- (a) shall be equipped with a suitable braking device on each castor or wheel; and
 - (b) shall have the brakes applied when a worker is on the scaffold.
- O. Reg. [213/91](#), s. 129 (1).
- (2) A scaffold mounted on castors or wheels shall be equipped with guy wires or outriggers to prevent its overturning if the height of the scaffold platform exceeds three times the least lateral dimension of the scaffold,
- (a) measured at the base of the scaffold; or
 - (b) if outriggers are used, measured between the outriggers. O. Reg. [213/91](#), s. 129 (2).
- (3) No scaffold mounted on castors or wheels that has a scaffold platform more than 2.4 meters above the base shall be moved when a worker is on it unless,
- (a) the worker is wearing a full body harness as part of a fall arrest system attached to a fixed support; and
 - (b) the scaffold is being moved on a firm level surface. O. Reg. [213/91](#), s. 129 (3).
- 135.** (1) A scaffold platform or other work platform,
- (a) shall be at least 460 millimeters wide;
 - (b) if it is 2.4 meters or more above a floor, roof or other surface, consist of planks laid tightly side by side for the full width of the scaffold;
 - (c) shall be provided with a guardrail as required by section 26.3;
 - (d) shall be provided with a means of access as required by section 70;
 - (e) shall not have any unguarded openings; and
 - (f) shall have each component secured against slipping from its supports.
- O. Reg. [213/91](#), s. 135 (1); O. Reg. 527/00, s. 4.
- (2) A scaffold platform or other work platform made of sawn lumber planks shall have planks of number 1 grade spruce that do not have any defect affecting their load-carrying capacity and,
- (a) that bear a legible grade identification stamp or are permanently identified as being number 1 grade spruce;
 - (b) that are at least forty-eight millimeters thick by 248 millimeters wide;
 - (c) that are arranged so that their span does not exceed 2.1 meters;
 - (d) that overhang their supports by not less than 150 millimeters and not more than 300 millimeters; and
 - (e) that are cleated or otherwise secured against slipping. O. Reg. [213/91](#), s. 135 (2).

APPENDIX B

LEGISLATION

CANADA OCCUPATIONAL HEALTH AND SAFETY REGULATION SOR 86-304

NOTE

This section does not contain the full Canada Occupational Health and Safety Regulation 86-304 only selected passages

PART XII -- SAFETY MATERIALS, EQUIPMENT, DEVICES AND CLOTHING

General

12.1 Where

(a) it is not reasonably practicable to eliminate or control a health or safety hazard in a work place within safe limits, and

(b) the use of protection equipment may prevent or reduce injury from that hazard, every person granted access to the work place who is exposed to that hazard shall use the protection equipment prescribed by this Part.

SOR/94-263, s. 44(F); SOR/95-533, s. 2(F); SOR/2002-208, s. 39.

12.2 All protection equipment referred to in section 12.1

(a) shall be designed to protect the person from the hazard for which it is provided; and

(b) shall not in itself create a hazard.

12.3 All protection equipment provided by the employer shall

(a) be maintained, inspected and tested by a qualified person; and

(b) where necessary to prevent a health hazard, be maintained in a clean and sanitary condition by a qualified person.

Fall-Protection Systems

12.10 (1) Subject to subsection (1.1), every employer shall provide a fall-protection system to any person, other than an employee who is installing or removing a fall-protection system in accordance with the instructions referred to in subsection (5), who works

(a) from an unguarded structure or on a vehicle, at a height of more than 2.4 m above the nearest permanent safe level or above any moving parts of machinery or any other surface or thing that could cause injury to a person on contact;

(b) from a temporary structure at a height of more than 6 m above a permanent safe level;

or

(c) from a ladder at a height of more than 2.4 m above the nearest permanent safe level where, because of the nature of the work, that person is unable to use at least one hand to hold onto the ladder.

(1.1) Where an employee is required to work on a vehicle on which it is not reasonably practicable to provide a fall-protection system, the employer shall

(a) in consultation with the policy committee or, if there is no policy committee, the work place committee or the health and safety representative,

(i) perform a job safety analysis to eliminate or minimize the need for the employee to climb onto the vehicle or its load, and

(ii) provide every employee who is likely to climb onto the vehicle or its load with training and instruction on the safe method of climbing onto and working on the vehicle or its load;

(b) make a report in writing to the regional health and safety officer setting out the reasons why it is not reasonably practicable to provide a fall-protection system and include the job safety analysis and a description of the training and instruction referred to in paragraph (a); and

(c) provide a copy of the report referred to in paragraph (b) to the policy committee or, if there is no policy committee, the work place committee or the health and safety representative.

(1.2) The job safety analysis, training and instruction referred to in paragraph (1.1)(a) shall be reviewed every two years in consultation with the policy committee or, if there is no policy committee, the work place committee or the health and safety representative.

(2) The components of a fall-protection system shall meet the following standards:

(a) CSA Standard Z259.1-1976, *Fall-Arresting Safety Belts and Lanyards for the Construction and Mining Industries*, the English version of which is dated November, 1976, as amended to May, 1979 and the French version of which is dated April, 1980;

(b) CSA Standard Z259.2-M1979, *Fall-Arresting Devices, Personnel Lowering Devices and Life Lines*, the English version of which is dated November, 1979 and the French version of which is dated October, 1983; and

(c) CSA Standard Z259.3-M1978, *Lineman's Body Belt and Lineman's Safety Strap*, the English version of which is dated September, 1978, as amended to April, 1981 and the French version of which is dated April, 1980, as amended to April, 1981.

(3) The anchor of a fall-protection system shall be capable of withstanding a force of 17.8 kN.

(4) A fall-protection system that is used to arrest the fall of a person shall prevent that person

(a) from being subjected to a peak fall arrest force greater than 8 kN; and

(b) from falling freely for more than 1.2 m.

(5) Where an employee is about to install or remove a fall-protection system, the employer shall

(a) prepare written instructions for the safe installation or removal of the fall-protection system; and

(b) keep a copy of the instructions readily available for the information of the employee.

SOR/88-632, s. 50(F); SOR/94-263, s. 47(F); SOR/2002-379, s. 1.

Instructions and Training

12.15 (1) Every person granted access to the work place who uses protection equipment shall be instructed by the employer in the use of the equipment.

(2) Every employee who uses protection equipment shall be instructed and trained in the use, operation and maintenance of the equipment.

(3) Every person granted access to a work place shall be instructed in respect of the written emergency procedures referred to in paragraph 12.11(2)(d).

(4) The instructions referred to in subsections (2) and (3) shall be

(a) set out in writing; and

(b) kept by the employer readily available for examination by every person granted access to the work place.



APPENDIX C

ENGINEERED DRAWINGS FOR BARNs WITH SECOND AND THIRD FLOORS

NEW CONSTRUCTION:

1. Obtain generic drawings (attached) for your building requirements.
2. Obtain stamped drawings for your new barn construction from engineer.
3. Stamped drawings taken to Canadian Welders Bureau (CWB) certified welding shop to have ramps and guardrails fabricated.
4. Provide stamped drawings to builder to ensure that the required structures or framing is in place to support the ramps on second floor or pass through on third floor.
5. Building inspector can ensure that construction meets requirements from drawings.

EXISTING BARNs:

1. Obtain Generic drawings (attached) for your specific application:
 - Onus is on farmers to install the retrofits correctly and that all of the guidelines from the drawings are followed;
 - Farmer ensures that existing structures can support what is being proposed;
 - Ramps need to be in good condition and framing around doors needs to be sound;
 - Integrity of existing building and equipment must be ensured;
 - Existing construction materials must be stable;
 - Attachment points for ramps and doors must be sound.
2. Verify the framing in the barn:
 - Verify the stud sizes and spacing;
 - Verify the floor joist sizes and spacing;
 - Measure the door widths.
3. Local engineer inspects site to verify condition and site specific drawings can be created and stamped for permit approval.
4. Stamped site specific drawing used to obtain building permits for any structural modifications made to the buildings.
5. Stamped drawings taken to Canadian Welders Bureau (CWB) certified welding shop to have ramps and guardrails fabricated.
6. Installation of equipment completed by a competent person.
7. Once installation complete, final inspection conducted by engineer to ensure installation follows requirements of drawing.

DRAWING 1

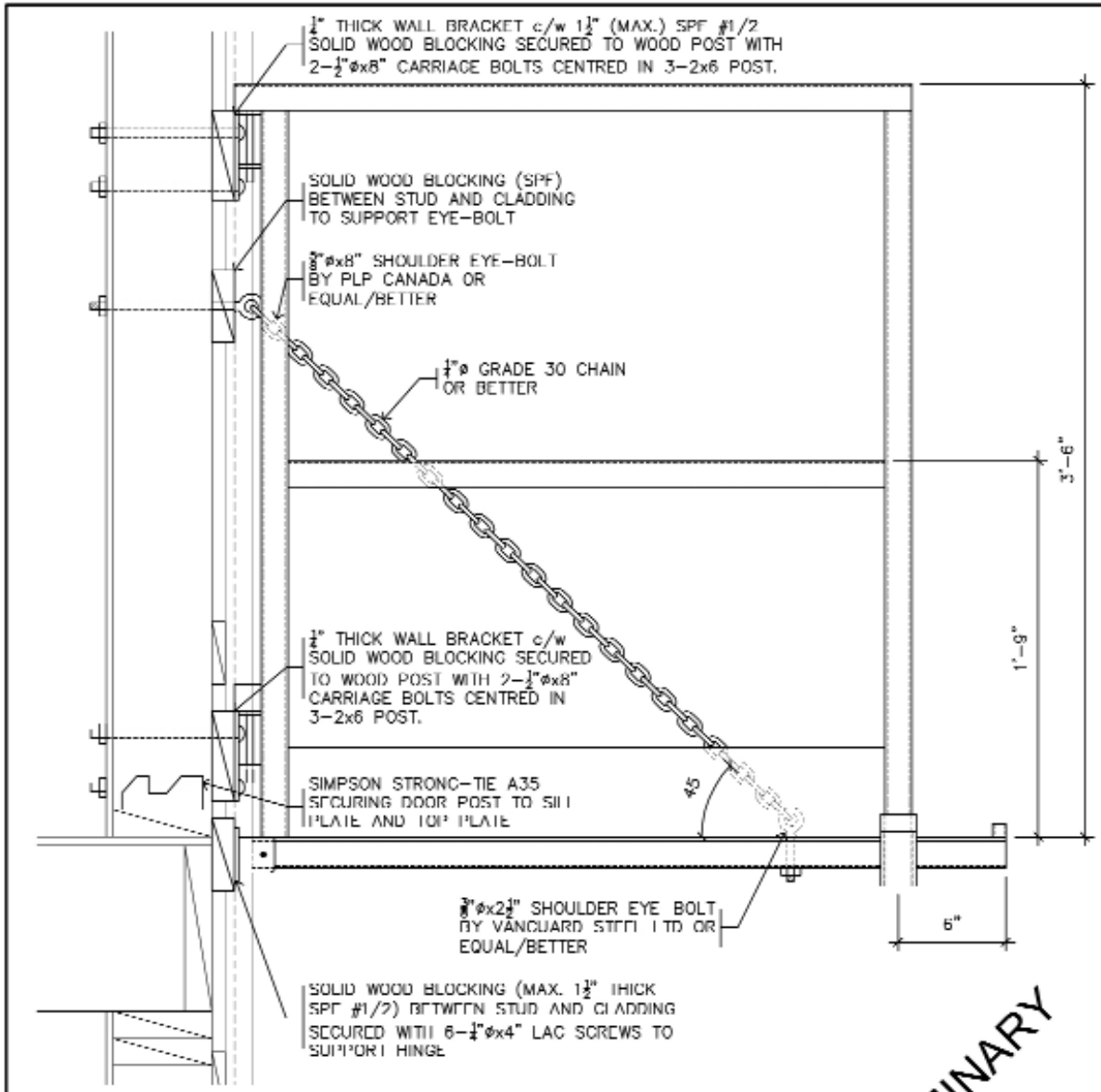



A
S1 2nd FLOOR LOAD-OUT - NEW GUARD & PLATFORM (ELEVATION)
SCALE: 1 1/2" = 1'-0"

PRELIMINARY

	Project title	BURNSIDE <small>R.J. Burnside & Associates Limited 282 Speedvale Ave W., Guelph, Ontario telephone (519) 823-4005 fax (519) 838-5477</small>		
	CHICKEN FARMERS OF ONTARIO PROPOSED 2nd FLOOR LOAD-OUT	Drawing title	Drawing No.	
ELEVATION - NEW PLATFORM AND GUARD	Drawn By C. LANKINEN	Checked By N/A	S1	
	Scale As Shown	Project No. PIA17400		

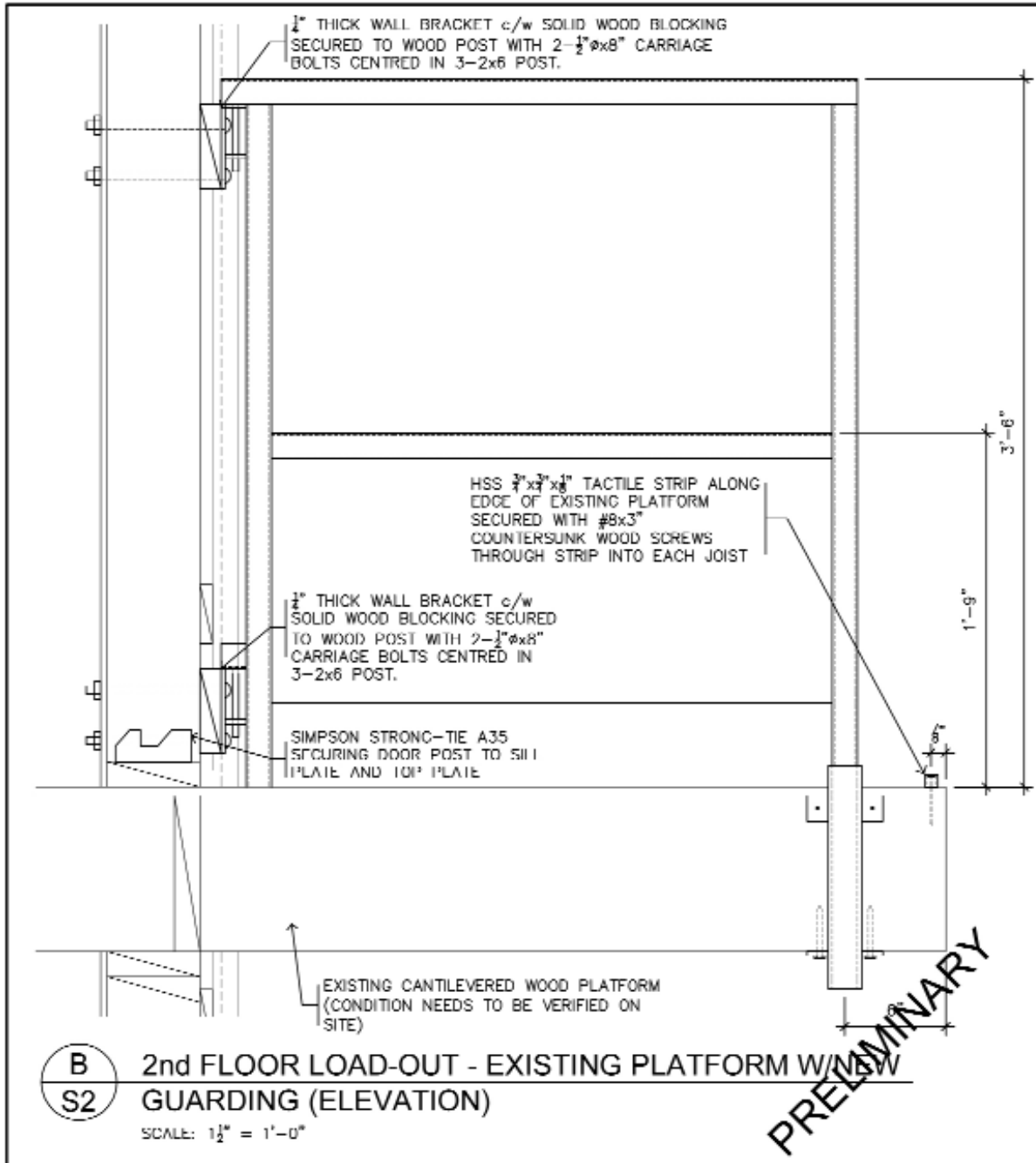
DRAWING 2



	<p>Project title</p> <p>CHICKEN FARMERS OF ONTARIO</p> <p>PROPOSED 2nd FLOOR LOAD-OUT</p>	 <p>BURNSIDE</p> <p>R.J. Burnside & Associates Limited 282 Speedvale Ave W., Guelph, Ontario telephone (519) 823-4005 fax (519) 838-5477</p>	
	<p>Drawing title</p> <p>ELEVATION - EXISTING PLATFORM W/NEW GUARD</p>	<p>Drawn By</p> <p>C. LANKINEN</p> <p>Scale</p> <p>As Shown</p>	<p>Checked By</p> <p>N/A</p> <p>Project No.</p> <p>PIA17400</p>
<p>Drawing No.</p> <p>S2</p>			

DRAWING 3

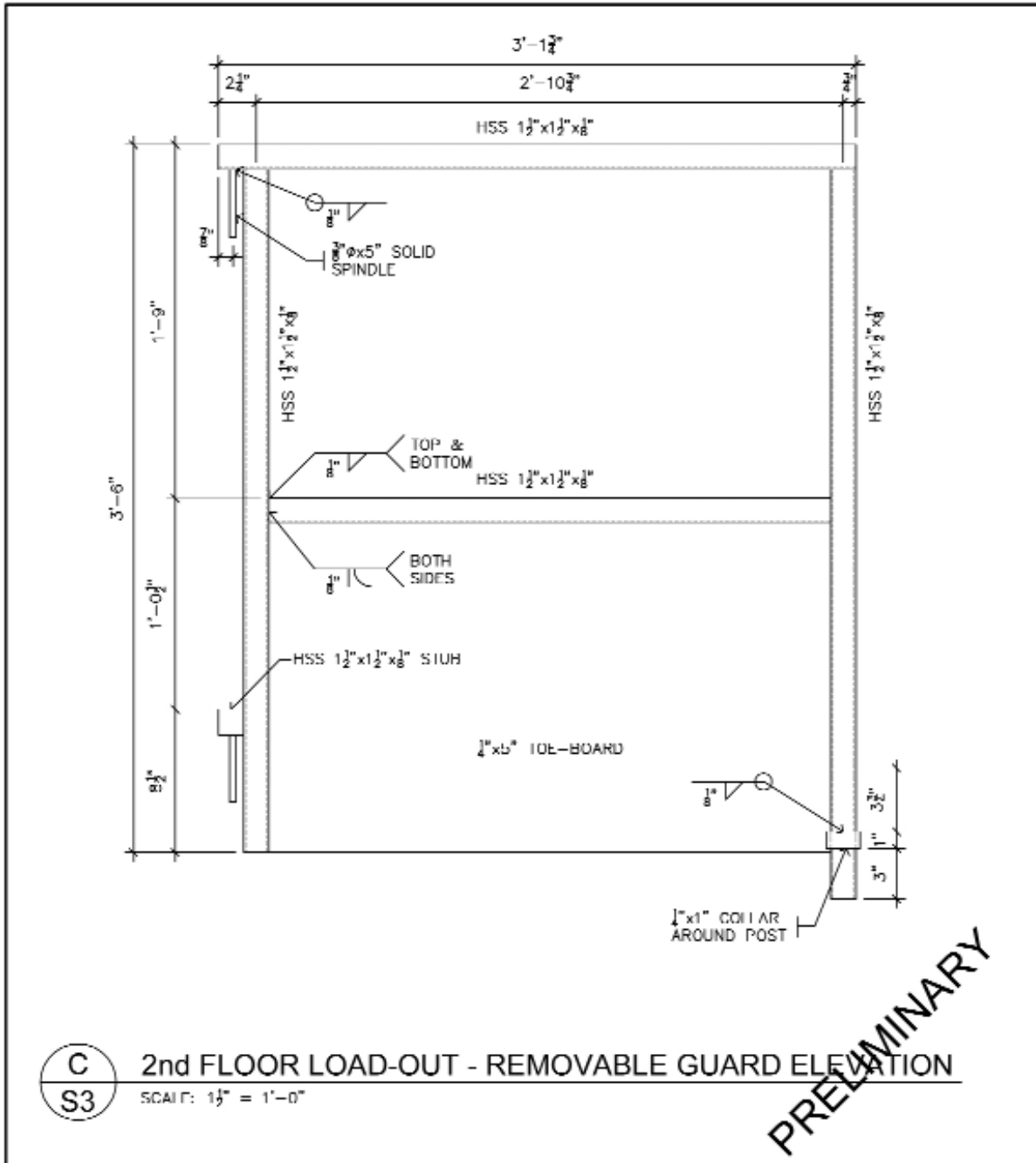

C
S3

2nd FLOOR LOAD-OUT - REMOVABLE GUARD ELEVATION

SCALE: 1 1/2" = 1'-0"

<p>Project title CHICKEN FARMERS OF ONTARIO PROPOSED 2nd FLOOR LOAD-OUT</p>	<p>BURNSIDE R.J. Burnside & Associates Limited 282 Speedvale Ave W., Guelph, Ontario telephone (519) 823-4005 fax (519) 838-5477</p>		
<p>Drawing title REMOVABLE GUARD ELEVATION</p>	<p>Drawn By C. LANKINEN Scale As Shown</p>	<p>Checked By N/A Project No. PIA17400</p>	<p>Drawing No. S3</p>

DRAWING 4

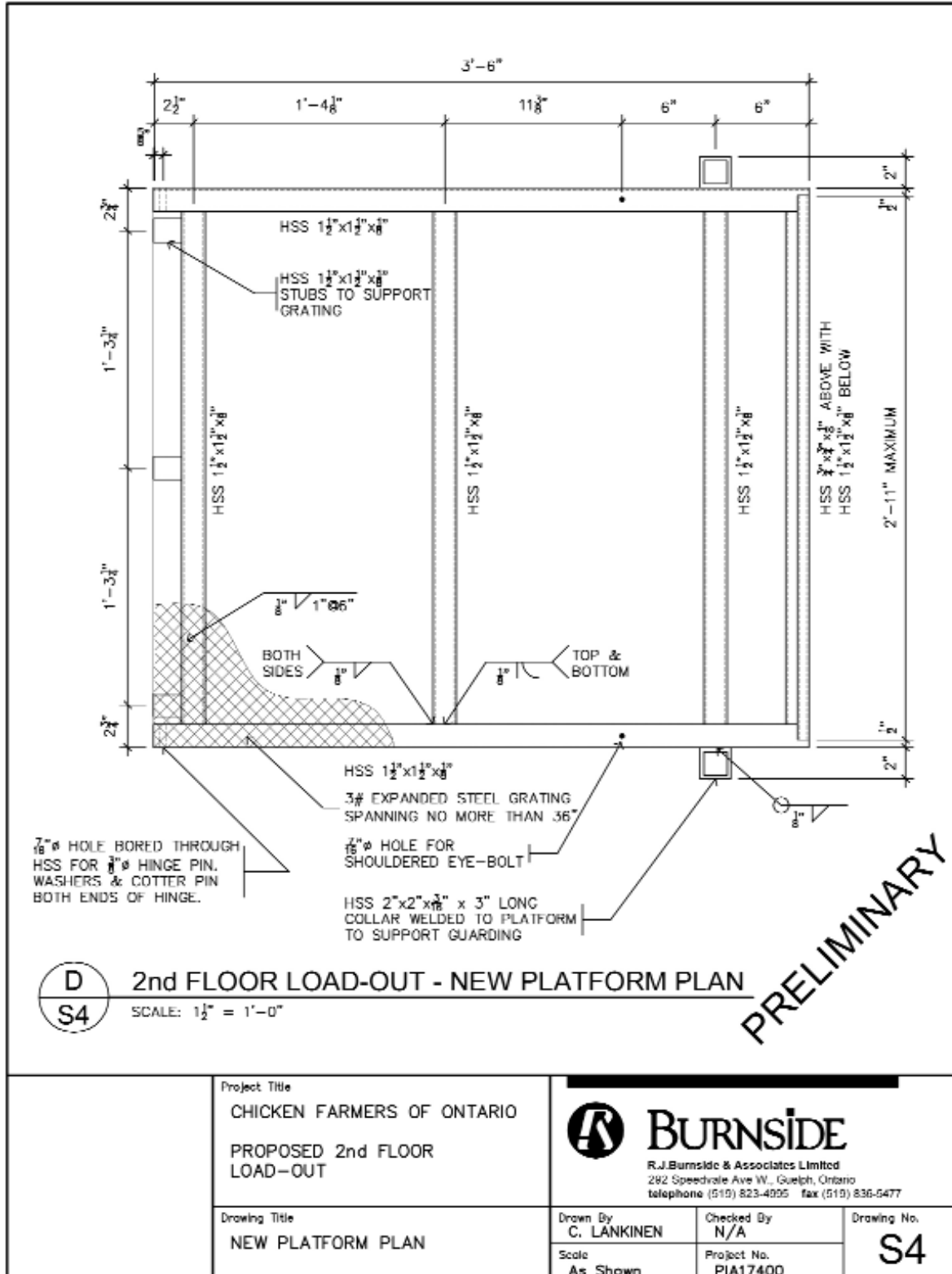

DRAWING 5

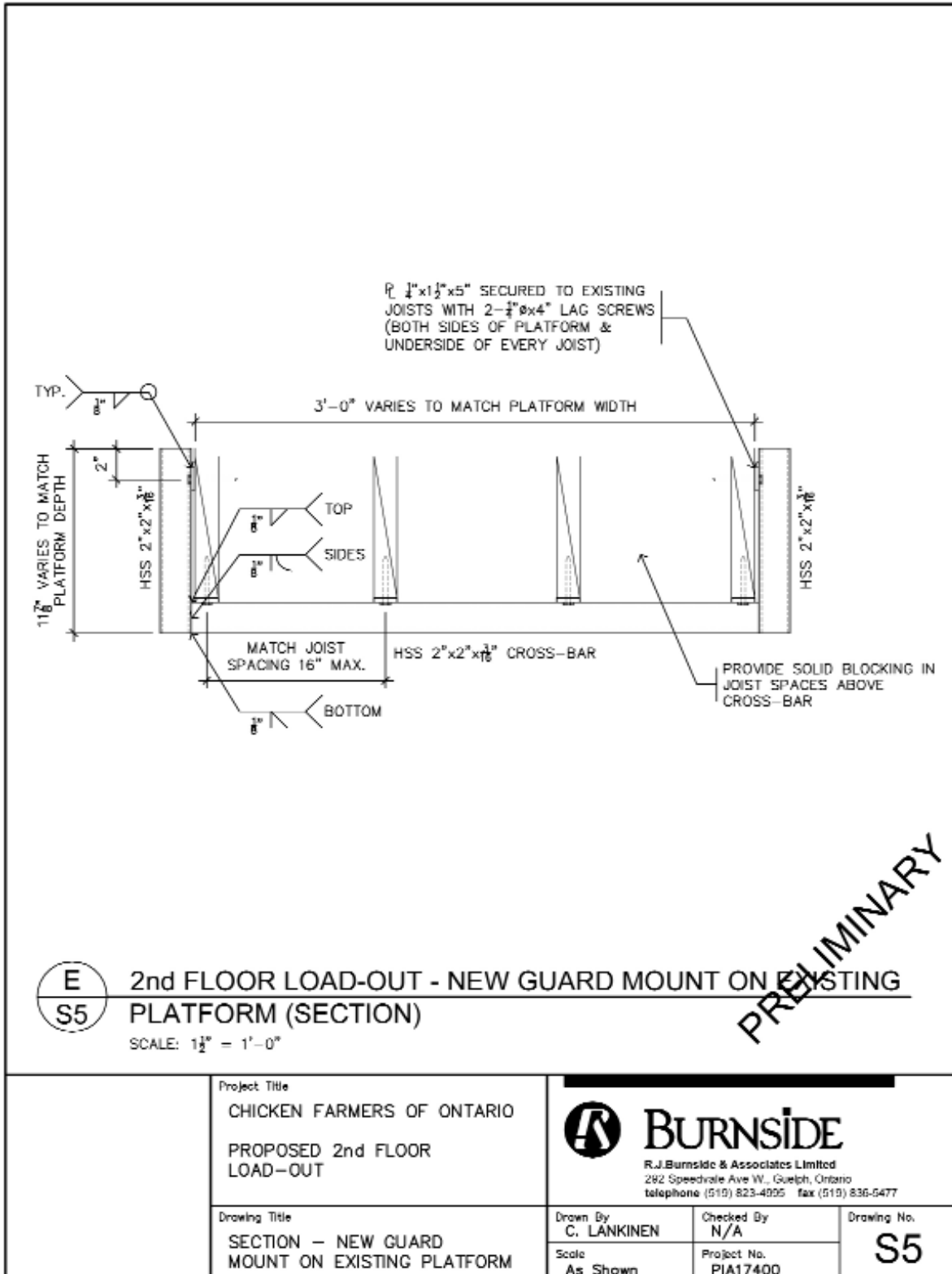

DRAWING 6

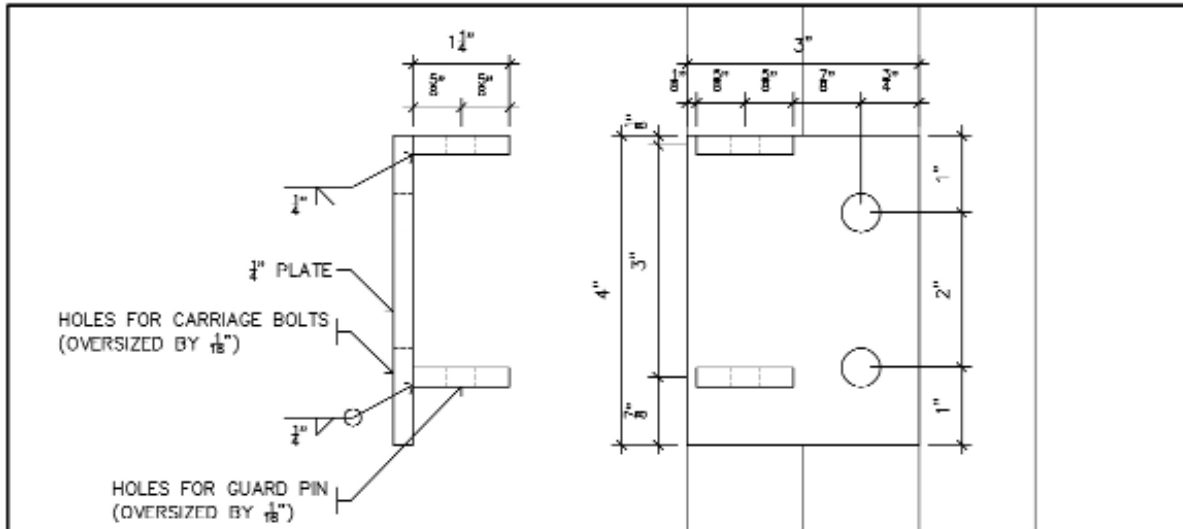

F 2nd FLOOR LOAD-OUT - PLATFORM WALL BRACKET
S6 SCALE: 6" = 1'-0"

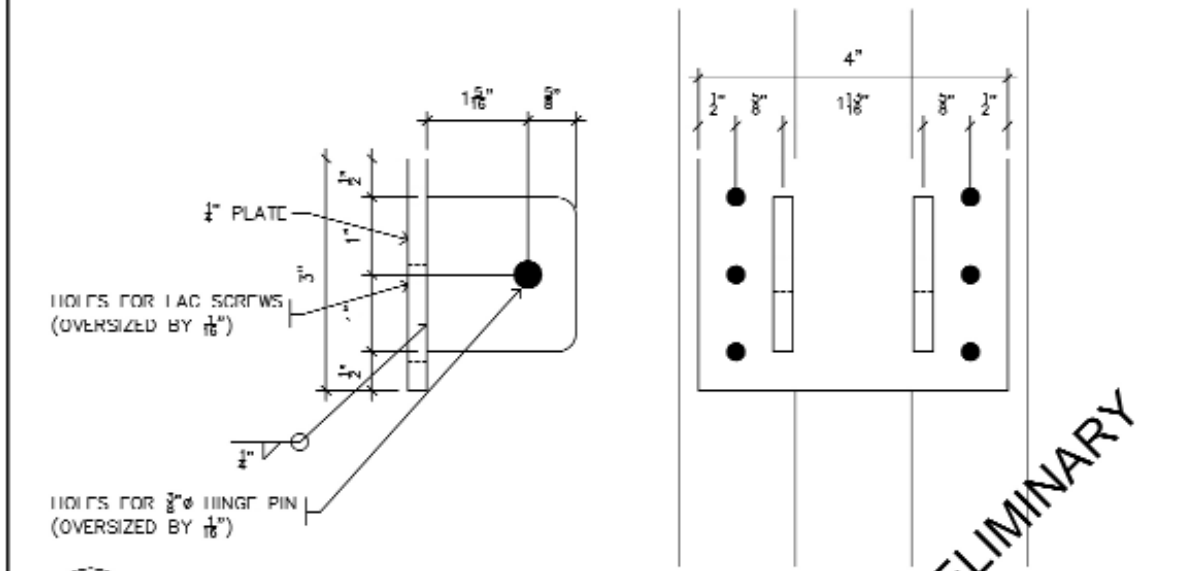

G 2nd FLOOR LOAD-OUT - PLATFORM HINGE
S6 SCALE: 6" = 1'-0"

PRELIMINARY

	<p>Project title CHICKEN FARMERS OF ONTARIO PROPOSED 2nd FLOOR LOAD-OUT</p>	 <p>BURNSIDE R.J. Burnside & Associates Limited 282 Speedvale Ave W., Guelph, Ontario telephone (519) 823-4005 fax (519) 838-5477</p>	
	<p>Drawing title PLATFORM CONNECTION DETAILS</p>	<p>Drawn By C. LANKINEN Scale As Shown</p>	<p>Checked By N/A Project No. PIA17400 Drawing No. S6</p>

DRAWING 7

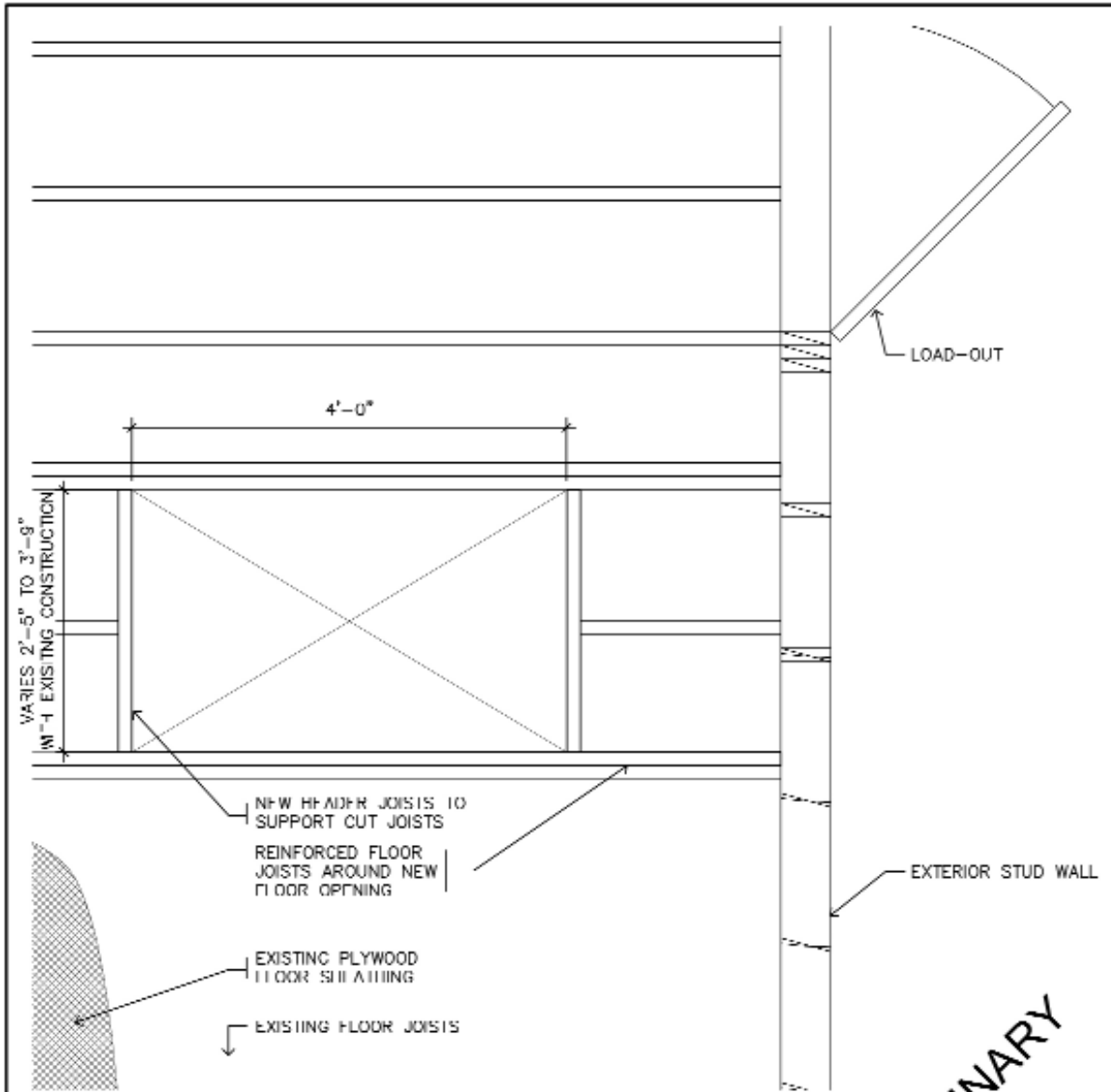

H 3rd FLOOR LOAD-OUT - FLOOR OPENING PLAN
S7 SCALE: 3/8" = 1'-0"

PRELIMINARY

	Project title CHICKEN FARMERS OF ONTARIO PROPOSED 3rd FLOOR LOAD-OUT	 BURNSIDE R.J. Burnside & Associates Limited 282 Speedvale Ave W., Guelph, Ontario telephone (519) 823-4005 fax (519) 838-5477	
	Drawing title FLOOR OPENING PLAN	Drawn By C. LANKINEN Scale As Shown	Checked By N/A Project No. PIA17400

DRAWING 8

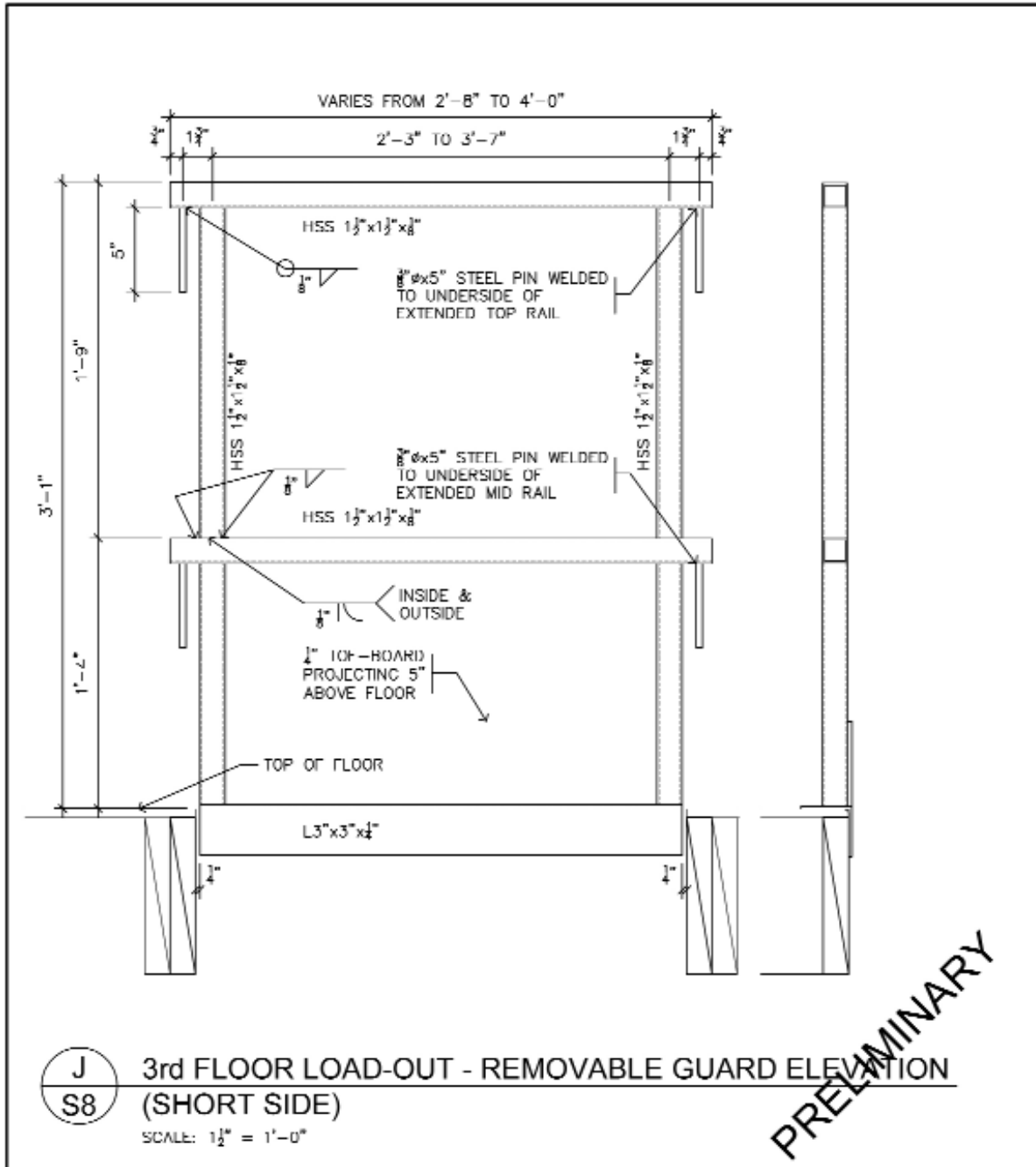

PRELIMINARY

	Project title CHICKEN FARMERS OF ONTARIO PROPOSED 3rd FLOOR LOAD-OUT	 BURNSIDE R.J. Burnside & Associates Limited 282 Speedvale Ave W., Guelph, Ontario telephone (519) 823-4005 fax (519) 838-5477	
	Drawing title REMOVABLE GUARD ELEVATION (SHORT SIDE)	Drawn By C. LANKINEN Scale As Shown	Checked By N/A Project No. PIA17400 Drawing No. S8

DRAWING 9

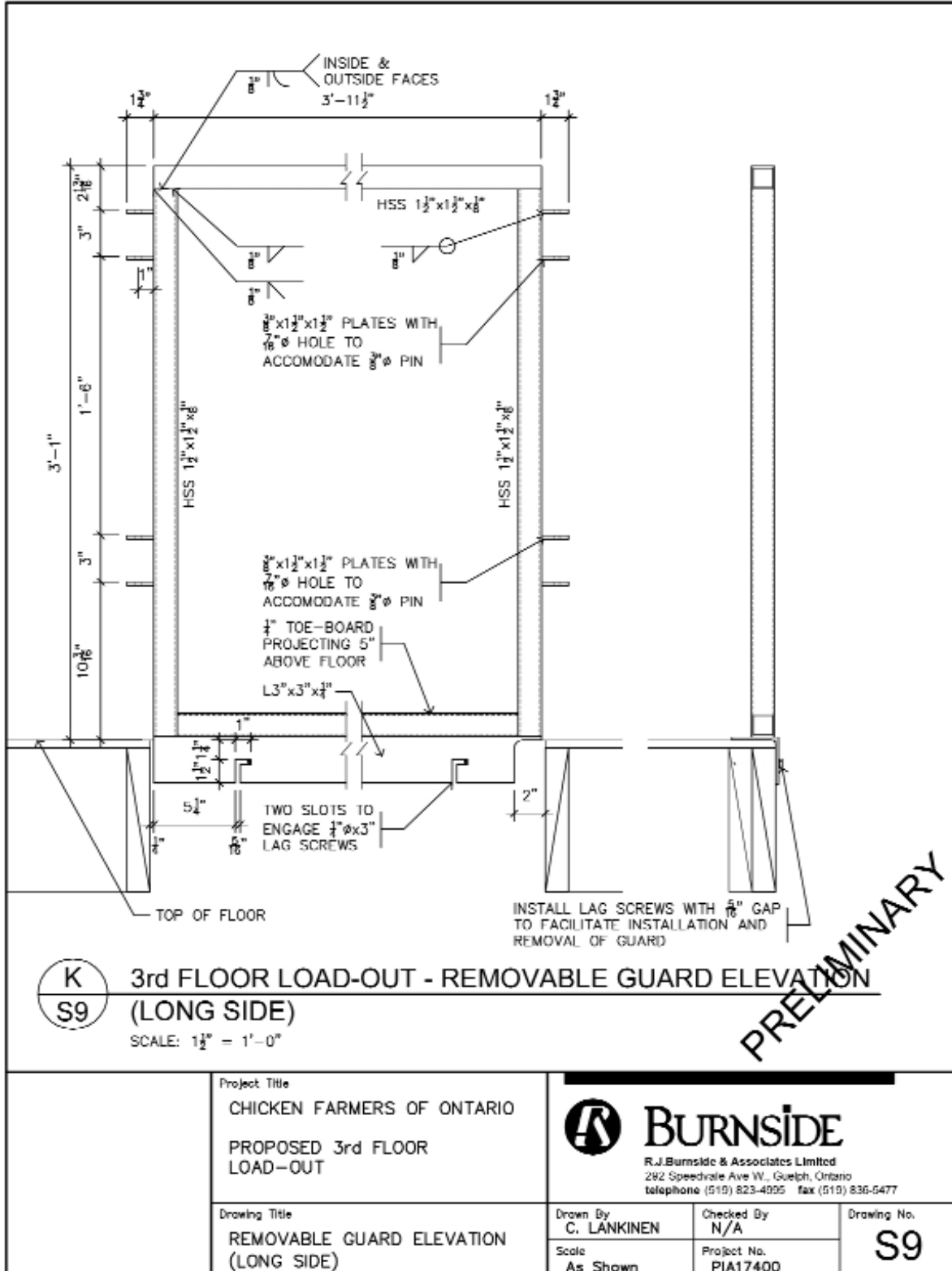

DRAWING 10

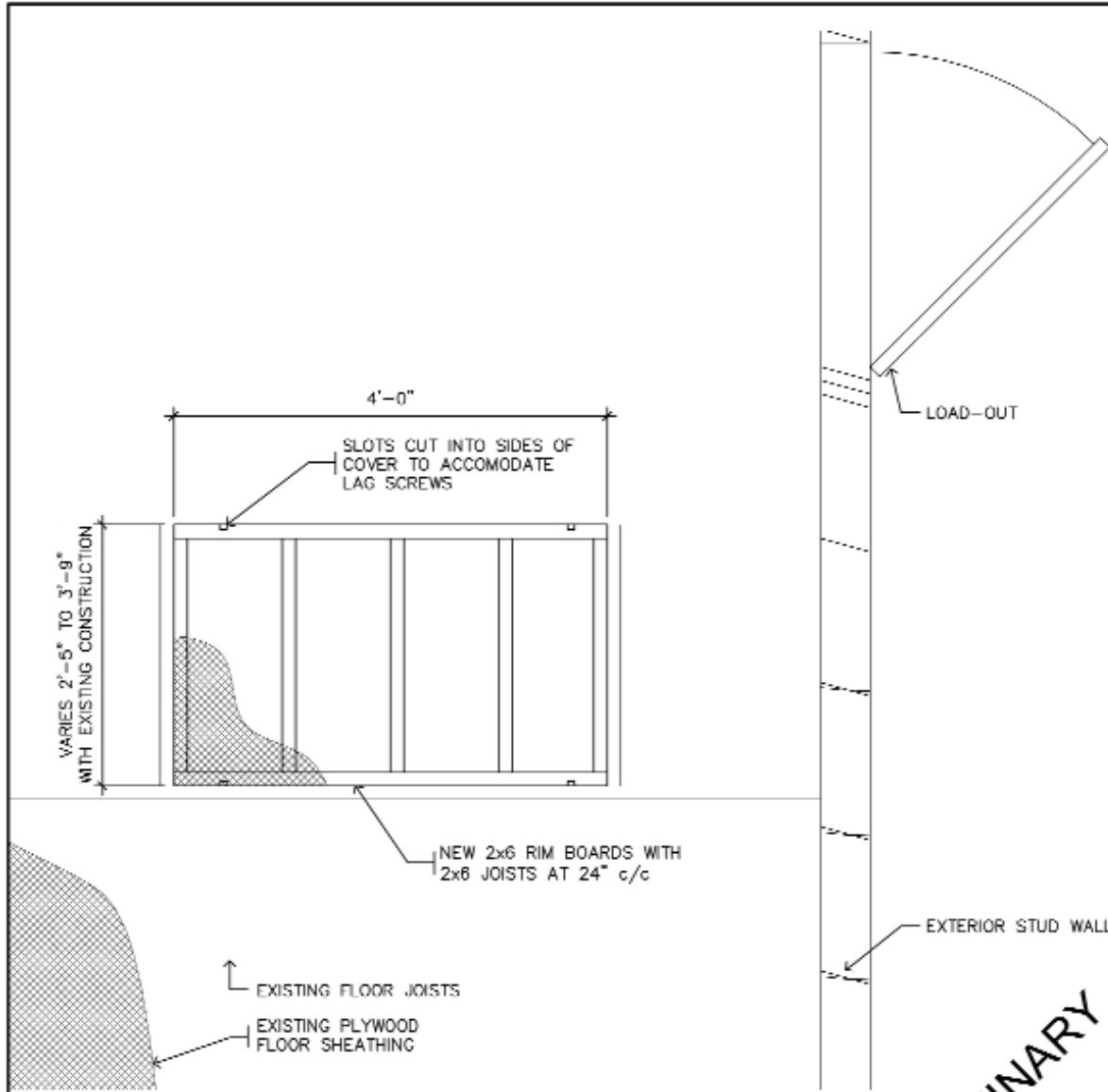



L 3rd FLOOR LOAD-OUT - FLOOR OPENING COVER PLAN
S10 SCALE: $\frac{3}{8}'' = 1'-0''$

PRELIMINARY

	Project Title CHICKEN FARMERS OF ONTARIO PROPOSED 3rd FLOOR LOAD-OUT	 BURNSIDE <small>R.J. Burnside & Associates Limited 282 Speedvale Ave W., Guelph, Ontario telephone (519) 823-4995 fax (519) 836-6477</small>		
	Drawing Title FLOOR OPENING COVER PLAN	Drawn By C. LANKINEN	Checked By N/A	Drawing No. S10
		Scale As Shown	Project No. PIA17400	

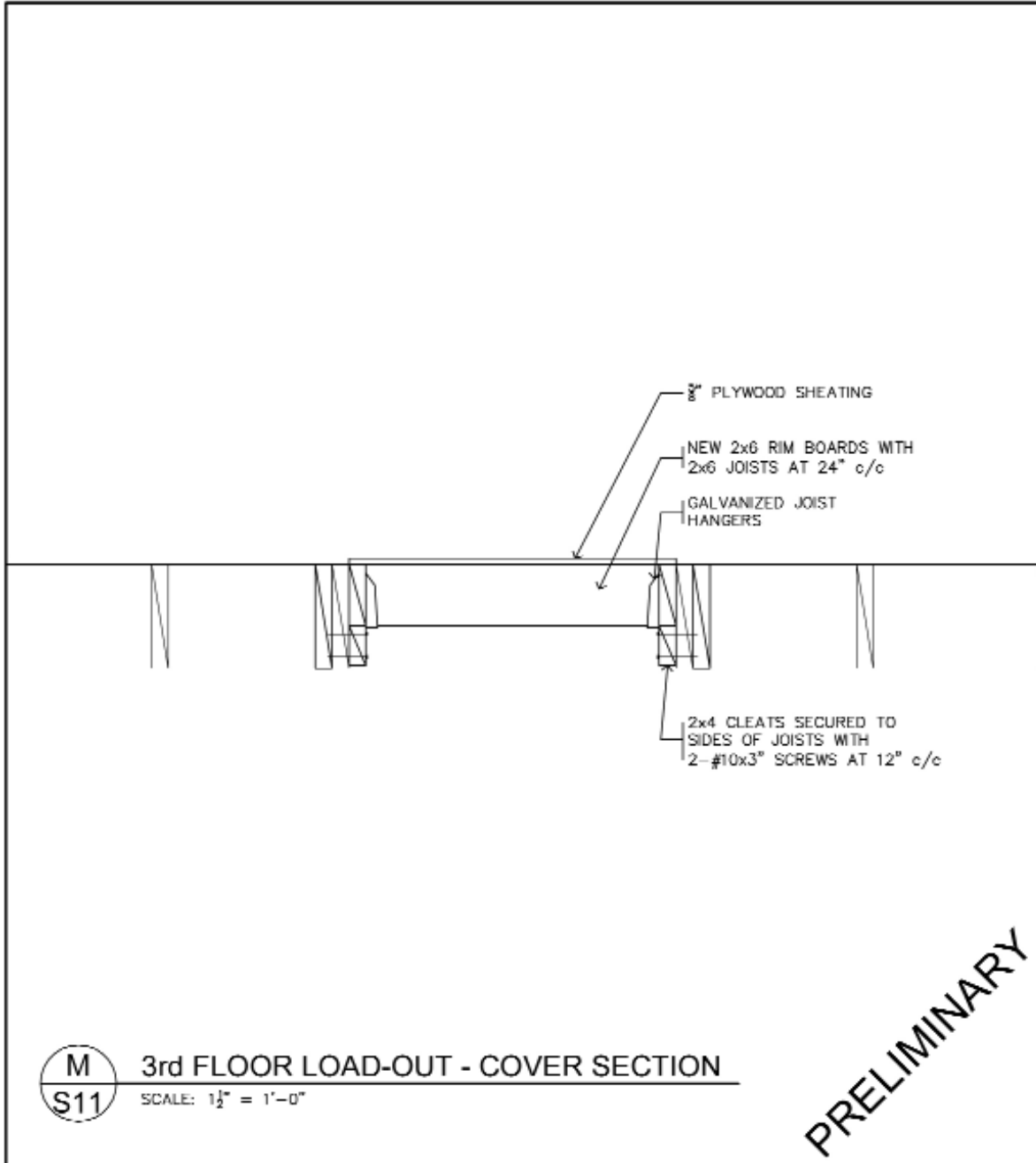
DRAWING 11



	Project Title CHICKEN FARMERS OF ONTARIO PROPOSED 3rd FLOOR LOAD-OUT	 BURNSIDE <small>R.J. Burnside & Associates Limited 292 Speedvale Ave W., Guelph, Ontario telephone (519) 823-4995 fax (519) 836-6477</small>	
	Drawing Title COVER SECTION	Drawn By C. LANKINEN	Checked By N/A
		Scale As Shown	Project No. PIA17400
		Drawing No. S11	

DRAWING 12

<p>STRUCTURAL NOTES</p> <p>1.0 GENERAL</p> <p>1.1 All work shall conform to the Ontario Building Code 2006 (OBC) and the National Farm Building Code of Canada 1995 (NFBC).</p> <p>1.2 Contractors and trades shall be experienced in the work required. Work shall be completed in accordance with accepted construction practise.</p> <p>1.3 Notify the engineer 48 hours in advance to schedule site review on existing framing around doors (for securement of platform and guards), existing framing on wooden platforms (for securement of guards), existing floor framing (for 3rd floor openings and guards), installation of platform(s) and installation of guards.</p> <p>1.4 These guards and platform structural drawings are to be read in conjunction with the structural drawings of the building.</p> <p>1.5 This set of drawings supersedes and replaces all previously released structural drawings.</p> <p>1.6 Do not scale the drawings.</p> <p>1.7 The contractor shall be responsible to verify all site conditions and measurements and report any discrepancies or unsatisfactory conditions immediately to the engineer, which may adversely affect the proper completion of the job before proceeding with the work.</p> <p>1.8 All work is to be performed in accordance with the Occupational Health and Safety Act and Regulations for Construction Projects.</p> <p>1.9 Load Conditions</p> <p><u>Load Paths:</u></p> <p><i>Gravity Forces</i> Resisted by joists and/or cantilevered platform(s) and transferred into walls/foundations.</p> <p><i>Lateral Forces</i> Resisted by guards and transferred to floor diaphragm.</p> <p>Applied gravity loads on new platforms: <i>Live = 100 psf</i></p> <p>Applied lateral loads on new guards: <i>Point load = 225 lbs</i></p> <p>2.0 DEMOLITION</p> <p>2.1 Prevent movement, settlement or damage of adjacent parts of the existing structure to remain. Provide bracing, shoring where required. Make good of damage and be liable for injury caused by demolition.</p> <p>2.2 Take precautions to support structural components and, if safety of building being demolished appears to be endangered, cease operations and notify engineer immediately before commencing any further.</p> <p>2.3 Phase demolition in stages as required, to safely remove components requiring removal.</p> <p>3.0 STRUCTURAL STEEL</p> <p>3.1 All structural steel design to conform to CAN3-S16.</p> <p>3.2 Structural steel to conform to CSA G40.21, structural Quality Steel 350W (300W for angles and channels).</p> <p>3.3 Bolts, washers and nuts to ASTM A325, High-Strength Bolts for Structural Steel Joints.</p> <p>3.4 Welding electrodes to CSA W48 and W59.</p> <p>3.5 Structural steel (guards and platforms) should be galvanized to maximize lifespan and reduce maintenance; alternatively steel can receive one coat of shop primer to CGSB 1-GP 40D or CISC/CPMA 2-75 and paint. Site touch up where necessary.</p> <p>3.6 Material specified to be galvanized to conform to G 164-M92 hot-dipped galvanized after fabrication.</p>			
<p>Project Title</p> <p>CHICKEN FARMERS OF ONTARIO</p> <p>GENERAL NOTES</p>		 <p>BURNSIDE</p> <p>R.J. Burnside & Associates Limited 282 Speedvale Ave W., Guelph, Ontario telephone (519) 823-4995 fax (519) 836-6477</p>	
<p>Drawing Title</p> <p>GENERAL NOTES</p>		<p>Drawn By</p> <p>C. LANKINEN</p> <p>Scale</p> <p>As Shown</p>	<p>Checked By</p> <p>N/A</p> <p>Project No.</p> <p>PIA17400</p>
		<p>Drawing No.</p> <p>S12</p>	

PRELIMINARY

CONTACT INFORMATION

Chicken Farmers of Ontario

P.O. Box 5035,
3320 South Service Road,
Burlington, ON, L7R 3Y8
Email: info@cfo.on.ca
Phone: 905-637-0025
Fax: 905-637-3464

Poultry Service Association

39 William Street
Elmira, ON N3B 1P3
Email: susan.tfio@sympatico.ca
Phone: 519-669-3350
Fax: 519-669-3826

Ontario Hatcheries Association

7660 Mill Rd., RR 4
Guelph, ON N1H 6J1
Phone: 519-763-6360
Fax: 519-837-0729

Association of Ontario Chicken Processors

7660 Mill Road
Guelph, ON N1H 6J1
Phone: 519-836-8383
Fax: 519-836-5015

OIPP - Ontario Independent Poultry Processors

RR#3
Moorefield, ON N0G 2K0
Email: johnslot@porchlight.ca
Phone: 519-638-3281
Fax: 519-588-3712